



## LEGAL NOTICE

### INVITATION TO SUBMIT QUOTATIONS

The Town of Smyrna will accept quotations on the Gas Meter sets for the Utilities Department. Bidders shall submit sealed quotations in the format specified in the Invitation to Submit Quotations no later than **10:00 a.m. June 20, 2018** at which time the bids will be publicly opened and read aloud. No bid may be withdrawn after the scheduled closing time for a period of 90 days. Bidding documents may be obtained at Smyrna Town Hall during regular business hours or [www.townofsmyrna.org](http://www.townofsmyrna.org). Quotations should be mailed or hand delivered to:

Rex S. Gaither  
Smyrna Town Hall  
**Sealed Bid on Gas Meter Sets**  
**June 20 @ 10:00 a.m.**  
315 South Lowry Street  
Smyrna, TN 37167

The Town of Smyrna will not discriminate in the purchase of all goods and services on the basis of race, color, religion, sex, national origin, age, disability or any other lawfully protected classification.

Verbal quotations, faxed quotations or quotations received after the closing date will not be accepted. The Town of Smyrna reserves the right to reject any and all bids, to waive technicalities or informalities and to accept any bid deemed to be in the best interest of the Town.

BY: REX S. GAITHER  
FINANCE DIRECTOR

TO BE RUN: June 7, 2018

---

COMPANY NAME

# TABLE OF CONTENTS

	PAGE
SECTION I - GENERAL INFORMATION	3
SECTION II - SPECIFICATIONS AND PRICE QUOTATION	5
INSURANCE REQUIREMENTS	6
AGREEMENT	10
SECTION III – SPECIFICATION COMPLIANCE	13
ATTACHMENT A	14
SPREADSHEET & DRAWINGS	

## **SECTION I – GENERAL INFORMATION**

- A. The Town of Smyrna desires to purchase gas meter sets for the Utilities Department.

Location of Smyrna Town Hall:  
315 South Lowry Street  
Smyrna, TN 37167

Delivery Locations:  
Gas: 108 G Street, Smyrna  
Water & Sewer: 106 G Street, Smyrna  
Call for delivery appointment.

- B. Questions should be directed to John Nokes (615) 887-1934 or Aubrey Blanks (615) 459-9742 ext. 2109. E-mail address: [john.nokes@townofsmyrna.org](mailto:john.nokes@townofsmyrna.org) or [aubrey.blanks@townofsmyrna.org](mailto:aubrey.blanks@townofsmyrna.org).
- C. The Town of Smyrna reserves the right to reject any and all bids, to waive technicalities or informalities and to accept any bid deemed to be in the best interest of the Town. No bid may be withdrawn after the scheduled closing time for a period of 90 days.
- D. The bidder shall abide by and comply with the true intent of the specifications and not take advantage of any unintentional error or omission, but shall fully address the full intent and meaning of each aspect of the specifications.
- E. **Equals must be pre-approved by John Nokes or Aubrey Blanks prior to bid opening. All items to be ordered as needed.** Quantities are **estimated** on annual usage.
- F. All materials in the bid documents have been placed into specific categories within each department. Each category shall be considered as a whole and not broken apart (See example in Attachment A).
- G. Section II, III and contract Agreement shall be **completed** and **included** as an integral part of each bidders proposal. Successful bidder will be expected to enter into a contract Agreement with the Town. Agreement shall be signed, but not dated, by the proper business representative and submitted **with** the bid proposal. An executed contract will be forwarded to winning vendor after Council approval.
- H. Freight shall be paid by vendor and should be **included** in unit price bid.
- I. The Town is a tax exempt organization.
- J. Mail is delivered after 11:00 a.m. Monday through Friday.
- K. Bid quotations **must** be submitted on the Town's quotation page(s). No exceptions.
- L. If you or your company wishes to be retained on the bid list please return either a bid or a "No Bid" response to this invitation.
- M. THIS ORDER WILL EXPIRE JUNE 30, 2019.

N. By submission of this bid, each bidder/proposer and each person signing on behalf of any bidder certifies, and in the case of a joint bid each party thereto certifies as to its own organization, under penalty of perjury, that to the best of its knowledge and belief that each bidder is not on the list created pursuant to T.C.A. § 12-12-106 Iran Divestment Act.

[https://www.tn.gov/assets/entities/generalservices/cpo/attachments/List\\_of persons pu rsuant to Tenn. Code Ann. 12-12-106, Iran Divestment Act-July.pdf](https://www.tn.gov/assets/entities/generalservices/cpo/attachments/List_of_persons_pu rsuant_to_Tenn._Code_Ann._12-12-106,_Iran_Divestment_Act-July.pdf)

## **SECTION II – SPECIFICATIONS AND PRICE QUOTATION**

### Base Bid Schedule

See Attached Spreadsheets

All materials have been placed into specific categories within each department. Each category shall be considered as a whole and not broken apart. An example of the format is included in Attachment A.

The Town of Smyrna has included a spreadsheet with this document. The spreadsheet has been included for bidding convenience. Each bidder is responsible for the information and mathematical accuracy. Please check and double check your bid prior to submitting.

**Compliance with laws:**

The contractor must comply with all applicable federal and state law including the prevailing wage laws.

Contractor must provide adequate proof of insurance with the bid.

**INSURANCE REQUIREMENTS**

The Vendor shall purchase and maintain for the duration of the contract insurance against claims for injuries to persons or damages to property which may arise from or in connection with the performance of the work hereunder by the Vendor, its agents, representatives, employees or subcontractors.

**A. MINIMUM SCOPE AND LIMITS OF INSURANCE**

**1. Workers Compensation**

Workers Compensation insurance shall be in compliance with the State of Tennessee and shall be statutory. Employers Liability shall be included with a minimum limit of \$500,000 per accident/per disease/per employee.

**2. Commercial General Liability**

Commercial General Liability insurance shall have a minimum limit per occurrence of \$1,000,000 and a minimum general aggregate of \$2,000,000. It shall include completed operations, product liability and personal injury liability insurance.

**3. Automobile Liability**

Automobile Liability Insurance shall have a minimum combined single limit per occurrence of \$1,000,000. This insurance shall include third-party bodily injury and property damage liability for owned, hired, borrowed and non-owned automobiles.

**B. DEDUCTIBLES AND SELF-INSURED RETENTIONS**

Any deductibles or self-insured retentions must be declared to the Town of Smyrna. The Vendor shall be responsible for all deductibles and self-insured retentions.

**C. OTHER INSURANCE PROVISIONS**

The policies are to contain, or be endorsed to contain, the following provisions:

**1. General Liability and Automobile Liability Coverages**

a. The Town, its elected and appointed officials, agents, employees and volunteers shall be named as an additional insured as regards negligence by the vendor.

b. The Vendor's insurance shall be primary as respects the Town, its elected and appointed officials, agents, employees and volunteers. Any insurance or self-insurance maintained by the Town of Smyrna shall be excess and non-contributory of the Vendor's insurance.

**2. Workers Compensation and Employers Liability Coverage**

The insurer shall agree to waive all rights of subrogation against the Town, its elected and appointed officials, agents, employees and volunteers for losses arising from work performed by the Vendor for the Town of Smyrna.

3. All Coverages

- a. Coverage shall not be canceled, suspended, or voided by either party (the Vendor or the insurer) or reduced in coverage or in limits except after 30 days written notice has been given to the Town of Smyrna. Ten-day written notice of cancellation is acceptable for non-payment of premium. Notifications shall comply with the standard cancellation provisions in the Vendor's policy.
- b. Neither the acceptance of the completed work nor the payment thereof shall release the Vendor from the obligations of the insurance requirements or indemnification agreement.
- c. The insurance companies issuing the policies shall have no recourse against the Town of Smyrna for payment of premiums or for assessments under any form of the policies.
- d. Replacement certificates, policies or endorsements shall be provided to the Town for any such insurance expiring prior to the completion of services.
- e. Any failure of the Vendor to comply with reporting provisions of the policy shall not affect coverage provided to the Town, its elected and appointed officials, agents, employees and volunteers.

**D. ACCEPTABILITY OF INSURERS**

All required insurance shall be provided by a company or companies licensed to conduct business in the State of Tennessee. Insurance shall be underwritten by insurers with an A.M. Best Company ratings no less than an A.

**E. VERIFICATION OF COVERAGE**

The Vendor shall furnish the Town with Certificates of Insurance reflecting proof of required coverage. The Certificates for each insurance policy are to be signed by a person authorized by that insurer to bind coverage on its behalf. **The Certificates are to be received and approved by the Town before work commences and upon any contract renewal thereafter.**

Upon failure of the Vendor to furnish, deliver and maintain such insurance as requested, this contract, at the election of the Town, may be suspended, discontinued or terminated. Failure of the Vendor to purchase and/or maintain any required insurance shall not relieve the Vendor from any liability or indemnification under the contract.

The Certificate of Insurance naming the "Town of Smyrna" as **Additional Insured** shall be addressed to the attention of:

Town of Smyrna  
Department of Safety & Risk Management

ATTN: Kay Charles  
315 S Lowry St  
Smyrna, TN 37167

The Town reserves the right to request complete certified copies of all required insurance policies at any time.

**F. SUBCONTRACTORS**

Vendor shall include all subcontractors as insureds under its policies **OR** shall be responsible for verifying and maintaining the Certificates provided by each subcontractor. Subcontractors shall be subject to all of the requirements stated herein. The Town of Smyrna reserves the right to request copies of subcontractor's Certificates at any time.

**G. WORKERS' COMPENSATION INDEMNITY**

In the event Vendor is not required to provide or is exempt from providing workers' compensation coverage, the parties hereby agree that Vendor, its owners, agents and employees will have no cause of action against, and will not assert a claim against the Town of Smyrna, its elected and appointed officials, agents, employees and volunteers, under any circumstances. The parties also hereby agree that the Town of Smyrna, its elected and appointed officials, agents, employees and volunteers shall in no circumstance be, or considered as, the employer or statutory employer of Vendor, its owners, agents and employees. The parties further agree that Vendor is a wholly independent vendor and is exclusively responsible for its employees, owners, and agents. Vendor hereby agrees to protect, defend, indemnify and hold the Town of Smyrna, its elected and appointed officials, agents, employees and volunteers harmless from any such assertion or claim that may arise from the performance of this contract.

**HOLD HARMLESS AND INDEMNITY REQUIREMENT:**

Vendor shall indemnify and hold harmless, to the maximum extent permitted by law, the Town of Smyrna and its officers, agents, employees, volunteers, from and against any and all liability, damages, losses, (whether in contract or in tort, including personal injury, accidental death or property damage, and regardless, of whether the allegations are false, fraudulent or groundless), and costs (including reasonable attorney's fees, litigation, arbitration, mediation, appeal expenses) which in whole or in part are caused by the negligence, recklessness or intentional wrongful misconduct of the Vendor and persons employed by or utilized by the Vendor in Vendor's performance of this Agreement.

The vendor further agrees to protect, defend, and save the Town, its elected and appointed officials, agents, employees and volunteers while working in the scope of their duties as such, harmless from and against all claims, demands, and causes of action of any kind of character, including the cost of their defense, arising in favor of the vendor's employees or third parties on account of bodily or personal injuries, death or damage to property arising out of services performed or omissions of services or in any way resulting from the acts of omissions of the vendor and/or its agents, employees, subcontractors, representative of the Town under this agreement.



Pursuant to Tennessee Attorney General Opinion 93-01, the Town will not indemnify, defend or hold harmless in any fashion the Vendor from any claims arising from any failure, regardless of any language in any attachment or other document that the Vendor may provide.

**APPLICABLE LAW:**

Any contract resulting from this RFP shall be governed by and construed under the laws.



## **AGREEMENT**

This Agreement is made and entered into as of this \_\_\_\_ day of \_\_\_\_\_, 2018, by and between \_\_\_\_\_, a \_\_\_\_\_ (the “Bidder”) and the Town of Smyrna, Tennessee, a Tennessee municipal corporation (the “Town”) for the purpose of **Gas Meter Sets**.

**WHEREAS**, the Bidder has submitted a quotation for the provision of certain products and/or services to the Town, all in accordance with the terms of the Invitation to Submit Quotations attached hereto and incorporated herein by reference as if set forth at length verbatim as Exhibit A (the “ISQ”), and which Quotation from the Bidder is attached hereto and incorporated herein by reference as if set forth at length verbatim as Exhibit B (the “Quotation”); the ISQ and the Quotation, together with any and all ancillary documents thereto, shall be collectively referred to herein as the “Bid Documents”); and

**WHEREAS**, the Town now desires to accept the Bidder’s quotation, in accordance with the terms set forth in such Bid Documents.

**NOW, THEREFORE**, in consideration of the mutual covenants contained herein, and for other good and valuable consideration, the receipt and sufficiency of which is hereby acknowledged, the undersigned do hereby agree as follows:

1. Acceptance of Bid Documents. The terms of the Bid Documents, as incorporated herein by reference, are hereby accepted by the parties hereto. The Bidder hereby agrees to provide the goods and/or services contemplated by such Bid Documents in accordance with the terms set forth therein. The Town hereby accepts the Bidder’s quotation to provide the goods and/or services contemplated by such Bid Documents in accordance with the terms set forth therein.

2. Entire Agreement. This Agreement, including the exhibits and any other documents referred to herein or therein, which form a part hereof, contains the entire understanding of the parties with respect to its subject matter. There are no restrictions, agreements, promises, warranties, covenants or undertakings other than those expressly set forth herein or therein. This Agreement supersedes all prior written or oral agreements and understandings between the parties with respect to its subject matter and may not be altered, modified or amended, in whole or in part, except by the express written authorization and consent of the parties hereto.

3. Severability. This agreement constitutes the product of negotiations of the parties hereto and any enforcement of hereof will be interpreted in a neutral manner and not more strongly against any party based upon the source of the draftsmanship of this Agreement. If any provision of this Agreement shall be held invalid or unenforceable by a court of competent jurisdiction, the remaining provisions hereof shall continue to be fully effective.

4. Limitation of Liability. The Town of Smyrna shall not be liable for any loss, claim, expense or damage caused by, contributed to by or arising out of the acts or omission of Bidder or third parties, whether negligent or otherwise.

5. Warranties. The Bidder warrants to the Town that all materials and equipment furnished under this Contract will be new unless otherwise specified, and that all work will be of good quality, free from faults and defects, suitable for the purpose for which the materials and equipment are furnished, and in conformance with the Agreement. All work not conforming to these requirements, including substitutions not properly approved and authorized, may be considered defective.

6. Indemnification. The parties hereto agree that Vendor shall indemnify The Town for any and all claims of negligence, tortious conduct or otherwise unlawful acts committed by Vendor in the performance of their obligations under the terms of the original agreement or this addendum to agreement and Vendor agrees to pay any and all costs associated with the enforcement of the terms of this indemnity agreement by The Town, including but not limited to court costs, civil judgments, assessments or any other reasonable fees associated therewith. This clause shall survive the expiration or termination of the original contract or this addendum to agreement and shall remain in full force and effect until the expiration of any applicable statute of limitation. In addition, The Town is prohibited by Tennessee law, as a political subdivision of the State of Tennessee, to agree to indemnify any private or public Vendor or contracting party and all reference to the local government providing indemnification shall be null and void by attaching signature to this addendum.

7. Attorney Fees. The parties hereto agree that The Town shall be in no event liable for any attorney's fees which Vendor may incur due to breach of the original agreement or this addendum agreement by either party; and further, The Town shall not acquiesce to any term of the original contract/agreement that indicates or infers The Town may or shall be responsible for the fees of another party or the Vendor's attorney fees.

8. Mediation. The Town may, at its option, require the attempted resolution of any dispute arising under the original contract or this addendum to agreement by mediation prior to the filing of any lawsuit or other claim. Should any dispute arise, Vendor shall provide the Town notice of any intent to file suit by certified mail. The Town shall notify the Vendor of its intent to exercise its right to mediation within thirty (30) days of receiving such notice. If the Town does not exercise its right to mediation, Vendor may file suit. Any mediator selected under this clause shall be agreed upon by the parties and the costs of such mediation shall be divided and paid equally between the parties.

9. Governing Law. This Agreement shall be deemed to have been executed and delivered within the State of Tennessee, and the rights and obligations of the parties shall be construed and enforced in accordance with, and governed by, the laws of the State of Tennessee.

10. Applicable Law / Choice of Forum and Venue. The parties' choice of forum and venue shall be exclusively in the courts of Rutherford County, Tennessee. Any provision of the Agreement held to violate a law or regulation shall be deemed void, and all remaining provisions shall continue in force.

**IN WITNESS WHEREOF**, the undersigned have executed this Agreement as of the date set forth above.

**BIDDER:**

\_\_\_\_\_

By: \_\_\_\_\_

Title: \_\_\_\_\_

ATTEST:

---

TOWN OF SMYRNA, TENNESSEE

By: \_\_\_\_\_

Name: Mary Esther Reed

Title: Mayor

ATTEST:

\_\_\_\_\_  
Dianne Waldron, Town Clerk





- 1. PAINT INMEC
- 2. TEST 100# FOR 30 MIN.
- 3. ASSEMBLE AND SHIP

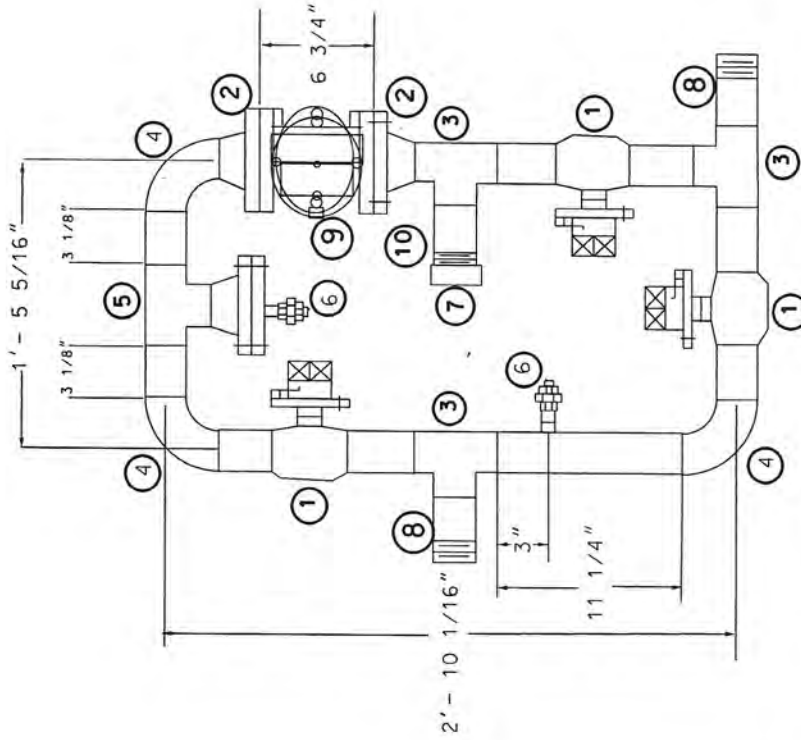

**ITEM QUAN DESCRIPTION**

ITEM	QUAN	DESCRIPTION
1	3	2" WELD END, RP, VALVE, ANSI 150
2	2	2" FLANGE, WELD END, FF, ANSI 150
3	3	2" WELD TEE
4	3	2" 90 ELL
5	1	2" STRAINER, ANSI 150
6	2	1/2" THREAD-0-LET w/ 1/2" NIPPLE, 1/2" VALVE AND 1/2" PLUG
7	1	2" CAP, THREADED
8	3	2" NIPPLE, 4" LONG

ITEM	QUAN	DESCRIPTION
9	1	3.5M METER WITH MERCURY TCI INDEX
10	2	2" PIPE, SCHEDULE 40
11	2	2" FLANGE KIT, FF, ANSI 150



TOWN OF SMYRNA  
 315 S. LOWRY STREET, SMYRNA, TN 37167  
 (615) 355-5711 fax: (615) 355-5799

**CUSTOMER** SMYRNA GAS SYSTEM  
**PROJECT** 3M ROTARY METER SET

3

- 1. PAINT INMEC
- 2. TEST 100 PSIG FOR 30 MIN.
- 3. ASSEMBLE AND SHIP

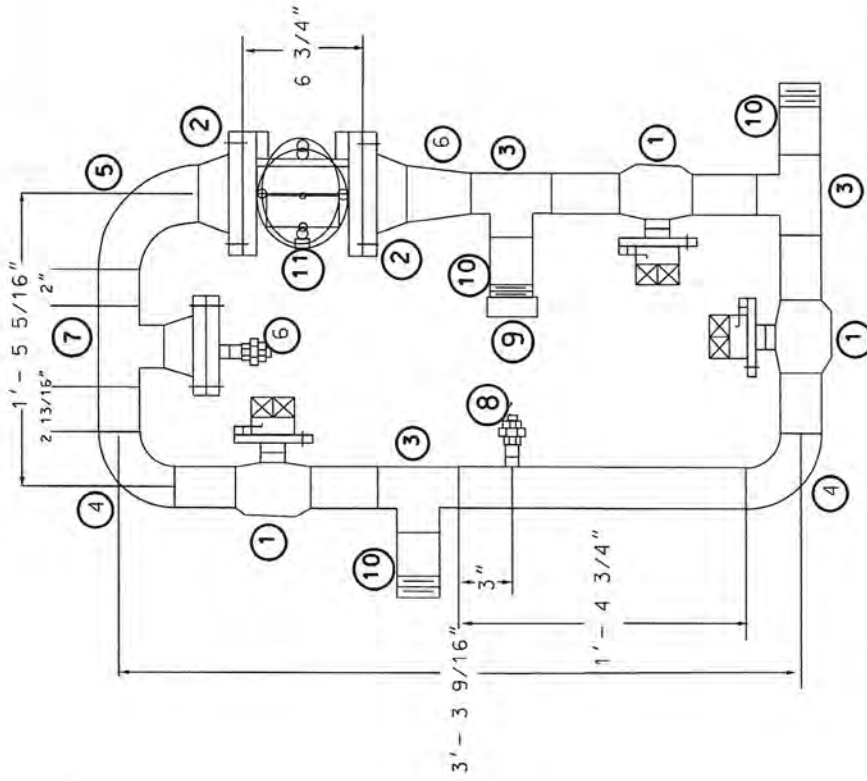

**DESCRIPTION**

ITEM	QUAN	DESCRIPTION
1	3	2" WELD END, RP, VALVE ANSI 150
2	2	3" FLANGE, WELD END, FF, ANSI 150
3	3	2" WELD TEE
4	2	2" 90 ELL
5	1	3" x 2" 90 ELL REDUCING
6	1	3" x 2" REDUCER
7	1	2" STRAINER
8	2	1/2" THREAD-O-LET w/ 1/2" NIPPLE, 1/2" VALVE AND 1/2" PLUG
9	1	2" CAP, THREADED
10	3	2" NIPPLE, 4" LONG
11	1	5.5M METER WITH MERCURY TCI INDEX
12	2 FT.	2" PIPE, SCHEDULE 40
13	2	2" FLANGE KIT, FF, ANSI 150



TOWN OF SMYRNA  
 315 S. Lowry Street, Smyrna, TN 37167  
 (615)355-5711 Fax: (615)355-5799

**CUSTOMER**  
 SMYRNA GAS SYSTEM

**PROJECT**  
 SM ROTARY METER SET

1



AEC		MATERIALS FOR FG9026-14M-RABO-M
DWG CODE	QTY	DESCRIPTION
1	3	2" WELD VALVE, 150# REDUCED PORT
2	1	2" T STRAINER
3	1	1" THREAD O LET
4	1	1"x3" SCH 40 TBE NIPPLE
5	1	1" LOCKWING BALL VALVE
6	1	1" SQUARE HEAD PLUG
7	1	1/2" THREAD O LET
8	1	1/2"x3" SCH 40 TBE NIPPLE
9	1	1/2" NEEDLE VALVE
10	1	1/2" SQUARE HEAD PLUG
11	1	3/4"x1/2"x4" SCH 40 SWAGED TBE NIPPLE
12	1	1/2" LOCKWING BALL VALVE
13	1	1/2" SQUARE HEAD PLUG
14	2	4"x2" SLIP ON FLAT FACE FLANGE, 150#
15	3	2" WELD TEE
16	1	2" WELD NECK RAISE FACE FLANGE, 150#
17	3	2" WELL ELL
18	1	2" THREADED CAP
19	2	2"x3" SCH 40 TOE NIPPLE
20	2	2"x15 1/2" SCH 40 PIPE
21	1	2"x5 1/2" SCH 40 PIPE
22	1	2"x6 1/2" SCH 40 PIPE
23	1	2"x2 1/2" SCH 40 PIPE
24	1	14M RABO MERCURY METER, AEC PN# R50026-14M-RABO-M
25	1	1/2"x2" GARLOCK RAISE FACE FLANGE GASKET KIT
26	1	1/2"x4" GARLOCK FLAT FACE FLANGE METER GASKET KIT

ITEM #24

RABO G250/14.0M  
14M RABO G250/14.0M METER

METER SIZE G250/14.0M (14000 CFH),  
FLANGE CONNECTION 4" FLANGED ANSI  
CLASS 150 (STD)  
MAOP 280 PSI (STD)  
GAS FLOW DIRECTION HORIZONTAL L TO R  
(STD)  
INDEX UNITS ENGLISH CF (STD)  
MODEL UNCORRECTED COUNTER CTR  
(STD)  
REGISTER MASKING 6 X 100 CF (STD)  
PROOF TARGET 100.3% ACCURACY (STD)  
PROOF READING AS % OF % ACCURACY  
(STD)  
PROOF DATA SENT AS CERTIFICATE WITH  
METER (STD)  
PETES PLUGS METER DIFF P PORTS (STD)  
CUSTOMER BADGE NO CUSTOMER BADGE  
(STD)  
CORRECTOR/AMR DEVICE YES (STD) WITH  
MERCURY MOUNTING BRACKET  
INDEX PULSE DEVICES SINGLE PULSE WITH  
CABLE  
INDEX PULSER TYPE E1 1 PULSE = 10 CF  
(STD)  
THERMOWELLS NONE (STD)  
SEAL METHOD STICKER METHOD (STD)  
STRAINER NONE (STD)  
GASKET AND BOLT INSTALL KIT NONE (STD)  
PACKAGING SINGLE PACK BOXES (STD)  
STOCK METER NON STOCK CUSTOM

WITH MININ MAX INSTRUMENT DRIVE W/ UMB

MMXUMB-BBBA0-AFA00-B5BA00-A0BAA0-  
HGAGA-AABFB-000-AA0A0-00000-00

Pipe	2.375 OD, 3.65 WT, 1.315 OD, 1.68 WT, 1.05 OD, 1.13 WT, .54 OD, .42 WT seamless steel pipe, conforming to specification API 5L Grade A 2S, Class 1A or B.
Threading	American National Standard taper pipe threads (NPT) in compliance with ANSI/ASME B1.20.1, threaded on both ends.
Welding	Welds will be fabricated in API-1104 to AEC standard AEC 10175 certified program.
Coating	Zinc plated with two part epoxy primer and urethane top coat.
Testing	Part to be testing at 428PSI for 30 minutes.

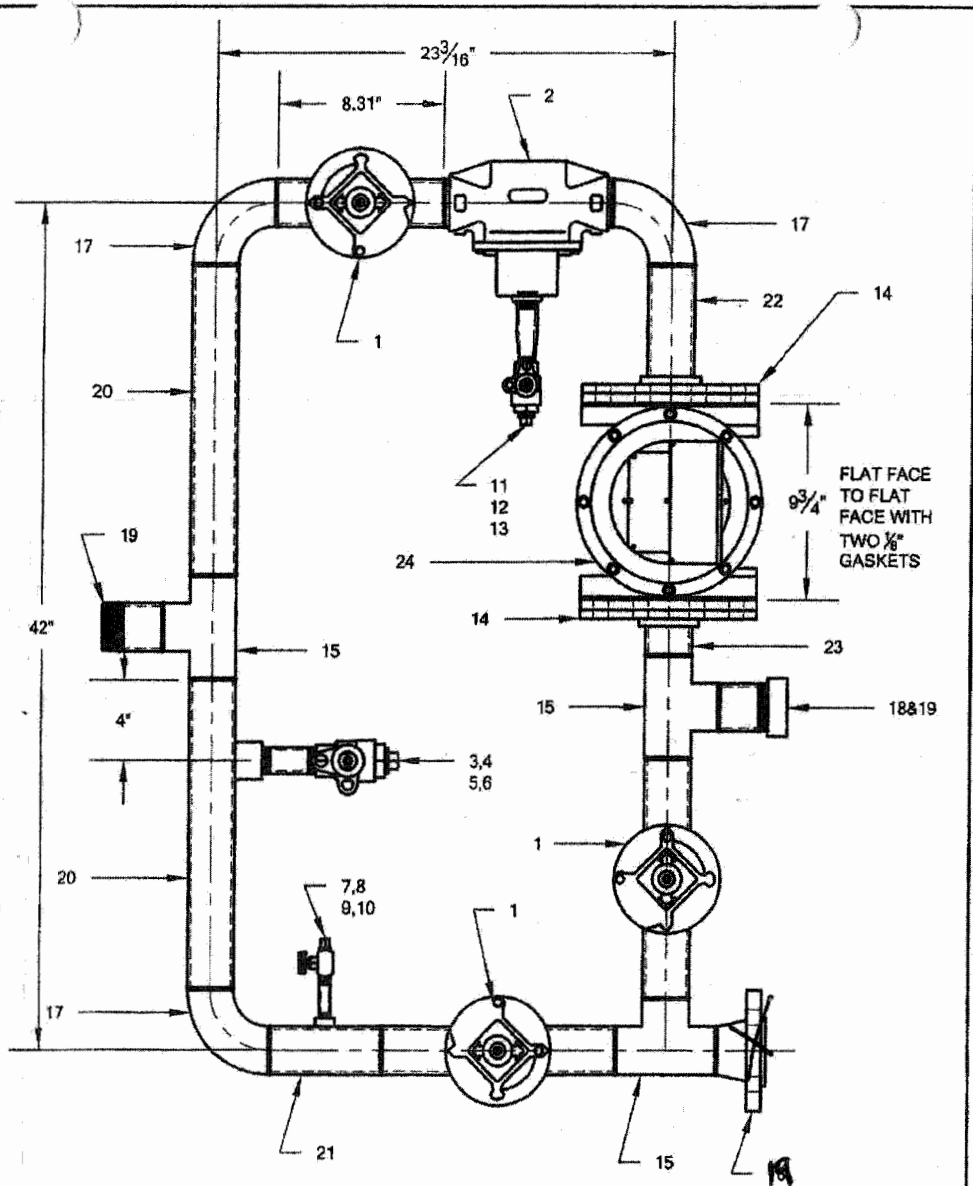

Purpose and Scope

This gas standard helps field personnel specify, order, and install gas meter connection kits.

Acronyms

AASHTO	Aeronautical National Pipe Threads
ANSI	American National Standards Institute
API	American Petroleum Institute
ASME	American Society of Mechanical Engineers
SMI	Black Malleable Iron
NPT	National Pipe Thread
OD	Outside Diameter
PSI	Pounds Per Square Inch
WT	Weight Per Foot

Application

Gas meter connection kits include several gas fittings used to install a gas meter set. The kits include the fittings from the service to the customer, already pre-assembled and pre-coated. These kits are ideal for uncorroded, inside or outside, gas meter set installations on new business or reconstruction jobs.

Safety

Using these gas meter connection kits should improve employee safety because many of the parts are pre-assembled and pre-coated, resulting in reduced employee risk exposures.

General

The finished product shall exhibit good machining practices with minimal surface blemishes.

UNLESS OTHERWISE SPECIFIED  
DIMENSIONS ARE IN INCHES  
TOLERANCES ARE:

FRACTIONS		±.015
DECIMALS	.XX	±.01
	.XXX	±.005
ANGLES		± 1°

NOTICE	ERN#	DATE:	APRVD BY:
The contents of this drawing is the sole property of Advance Engineering Corporation. This print and its contents shall not be traced or reproduced without prior written permission from Advance Engineering Corporation. It shall not be used directly or indirectly in any way detrimental to the interest of Advance Engineering Corporation.	MTR DSCPT ADJ	9-25-16	TJ

14M-9M		14M RABO METER SET	
PART#: FG9026-14M-RABO-M	SCALE= 1:9	DRAWN BY: E.A.C.	
DATE: 3-30-16	MATERIAL: SEE SPECS	APRVD BY:	
		CHECKED BY:	
		REV:	
CUSTOMER APPROVAL SIGNATURE:			

## Dimensions and Weights

	Units	3.5M/G65	5.5M/G100	9M/G160	14M/G250
A	in. [mm]	6.75 [171]	6.75 [171]	9.5 [241]	9.5 [241]
B	in. [mm]	7.56 [192]	7.56 [192]	10.08 [256]	10.08 [256]
C	in. [mm]	8.63 [219]	8.63 [219]	10.75 [273]	10.75 [273]
D	in. [mm]	3.78 [96]	5.43 [138]	5.16 [131]	6.14 [156]
E	in. [mm]	7.52 [191]	9.17 [233]	10.67 [271]	11.65 [296]
F	in. [mm]	11.26 [286]	14.61 [371]	15.83 [402]	17.76 [451]
G	in. [mm]	3.78 [96]	3.78 [96]	5.04 [128]	5.04 [128]
Nom. Pipe Size*	in. [mm]	2	3	3	4
Bolt Size, H		5/8" - 11	5/8" - 11	5/8" - 11	5/8" - 11
# Bolts / Flange		4	4	4	8
Bolt Circle, J	in. [mm]	4.75 [121]	6.00 [152]	6.00 [152]	7.50 [191]
Shipping Weight	lbs. [kg]	29.8 [14]	37.7 [17]	73.9 [34]	82.3 [37]
Carton Size	in.	18.3L x 1.6W x 12.6H			
	[mm]	465L x 270W x 320H			
		23.6L x 13.0W x 13.4H			
		600L x 330W x 340H			

\*ANSI Class 125/150 flat face flange connection

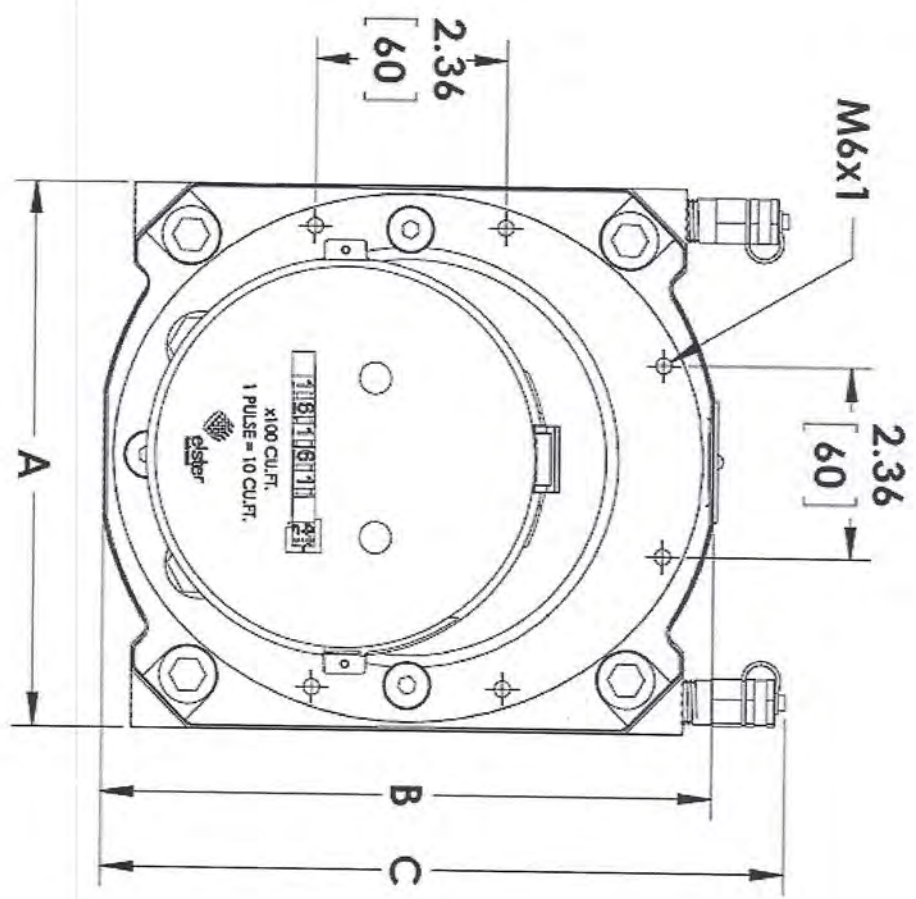
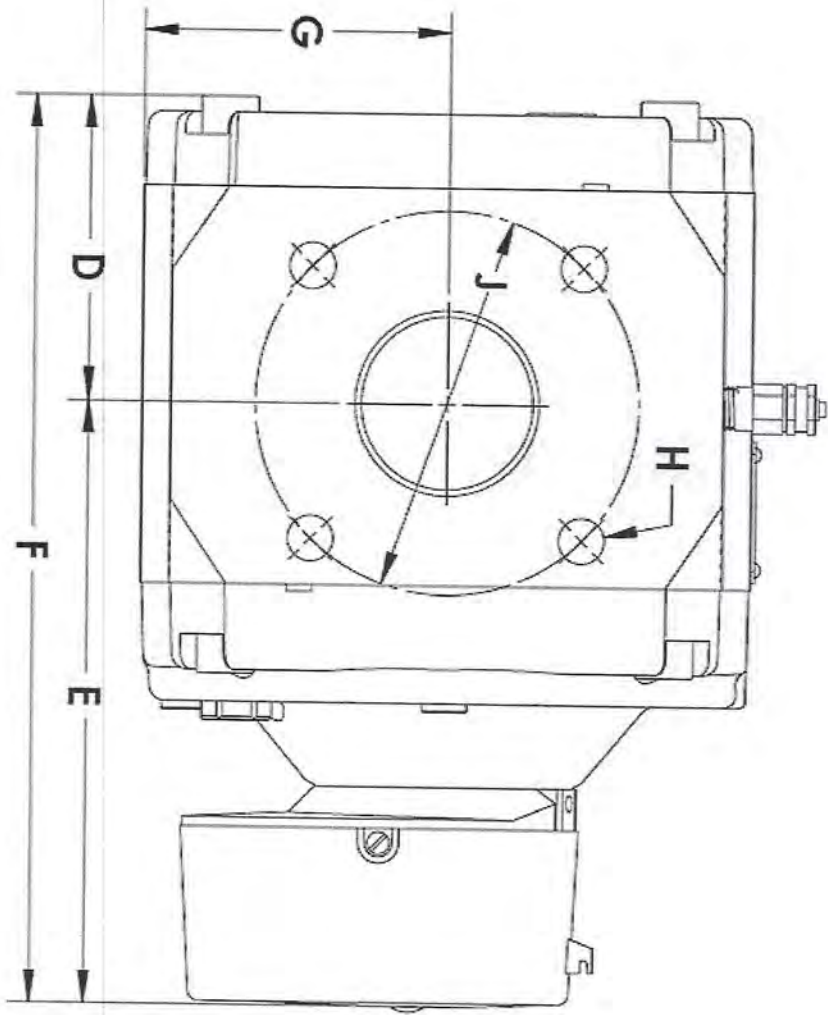

GAS	ITEM #	DESCRIPTION	SIZE	APPROVED PART #	ALTERNATE PART #	UNIT	EST QTY FY 18/19	BIDDER	UNIT PRICE	ESTIMATED DELIVERY TIME
		<b>PREFABRICATED GAS ROTARY METER SET</b>								
		<b>PAINT SHALL BE GRAY EPOXY</b>								
G	7	METER SET; 3.5M ROTARY METER SET - WITHOUT METER/EV	3.5M	See Drawing	N/A	EA	3			
G	8	METER SET; 5.5M ROTARY METER SET - WITHOUT METER/EV	5.5M	See Drawing	N/A	EA	2			
G	9	METER SET; 9 M ROTARY METER SET - WITHOUT METER/EV	9M	See Drawing	N/A	EA	1			
G	10	METER SET; 14 M ROTARY METER SET - WITHOUT METER/EV	14M	See Drawing	N/A	EA	1			